

134 Ball LPDDR2 Memory Support Oscilloscope Component Interposer

- Optimal Analog Validation
- Use with Existing Embedded / Mobile Designs
- Scope Probe Tips Designed into the Interposer
- Signals brought out to Probe Pads for Easy Connection
- Direct Attach to Target
- Electrically and Mechanically Non-Intrusive
- Support for LPDDR2 Memory Devices
 - Direct Attach to Target
 - 10.0x11.5mm Package Size
 - x16/x32 Data Width
 - 0.65mm Pitch
- S Parameters available for Simulation and Scope Filter Creation

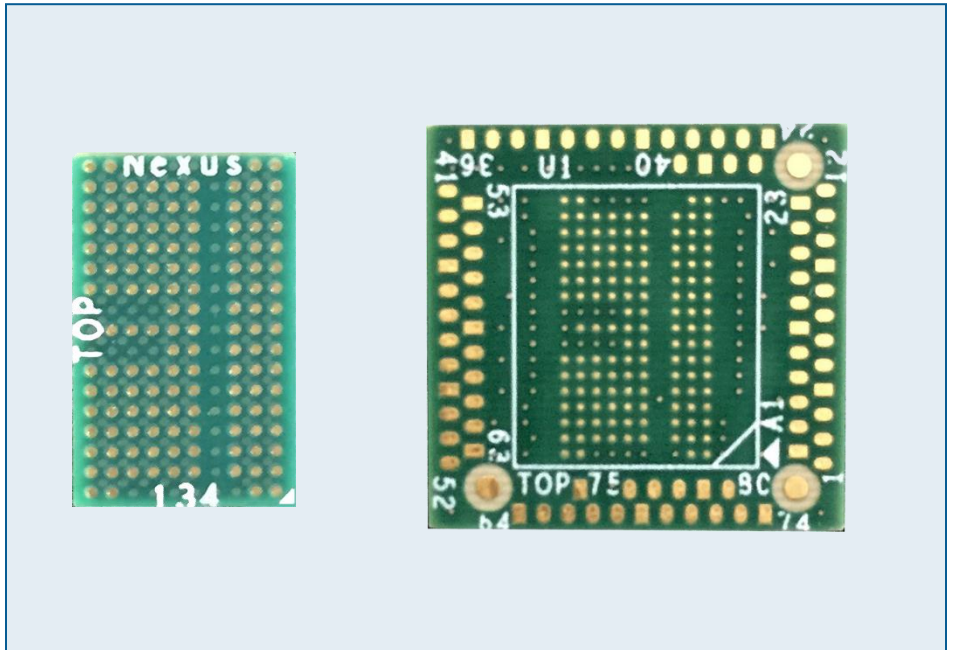

This Memory Component Interposer (MCI) BGA adapter has been designed to provide a high fidelity, easy to probe adapter that connects between your target Board and your memory component. Memory Component Interposers compliment the oscilloscope adapters providing a complete debug solution.

Memory Component Interposer Installation

Assemble the Memory Component Interposer onto the riser as shown in Figure 3 (Riser is optional). Care should be taken to ensure that the balls on the adapter align correctly with the riser on the target. Pin 1A needs to be matched to 1A on the user's board under test (Target).

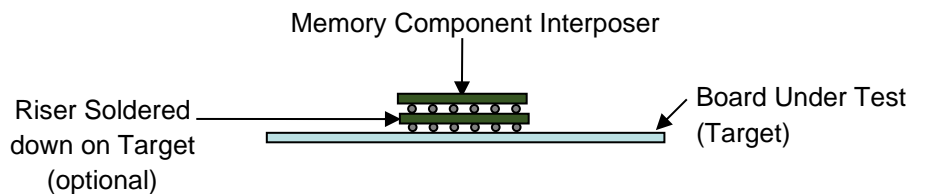

Figure 2 - Side view of the complete interposer installation

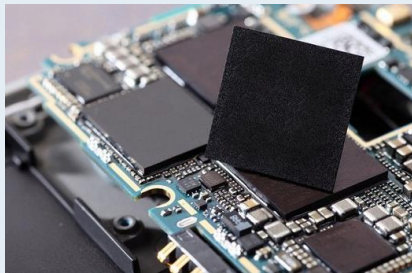

Figure 1 – LPDDR2 Memory

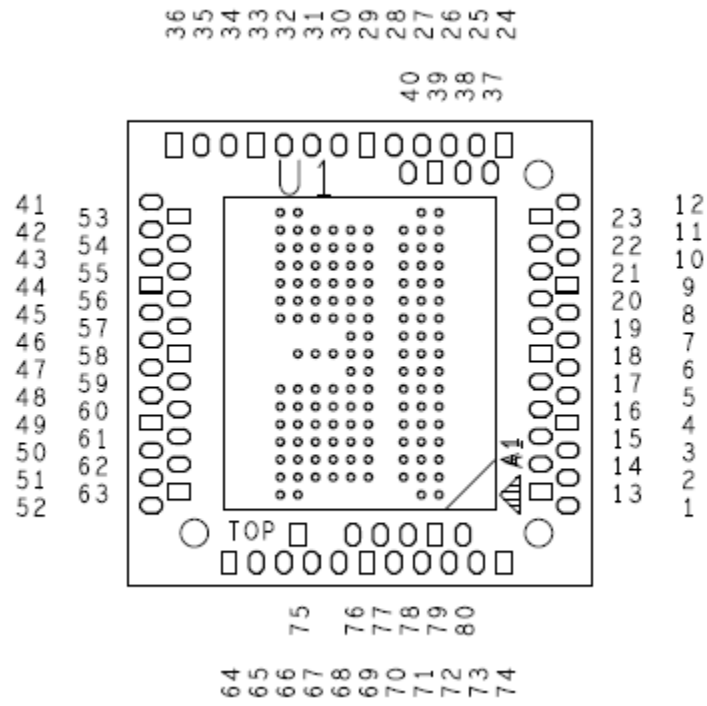

Figure 3 - Probe point locations top side

Oscilloscope Component Interposer Hardware

Connection to an oscilloscope is enabled by using oscilloscope memory component interposers. These controlled impedance; matched trace length interposers provide analog visibility using an oscilloscope. Signals are brought out to probe points that are designed to accommodate solder down probe tips. For more information, please see the [Nexus Soldering Guide](#). Removable oscilloscope probe tips can also be used to easily move the oscilloscope probe between signals for quick and accurate measurement.

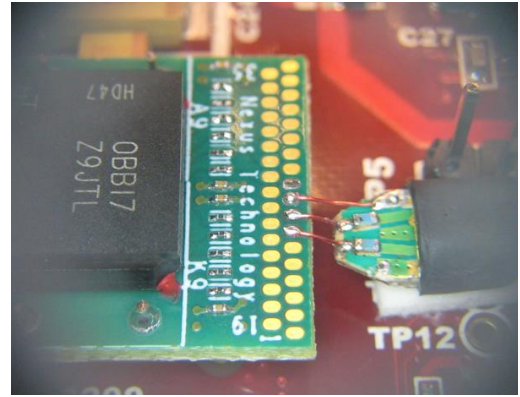

Figure 4 - Soldered down probe tips

Oscilloscope Analog Validation

Filter software available for your oscilloscope removes the effect of the oscilloscope interposer. Although these interposers are designed to optimize signal integrity, this feature removes even the slightest effect the adapter has from the oscilloscope display.

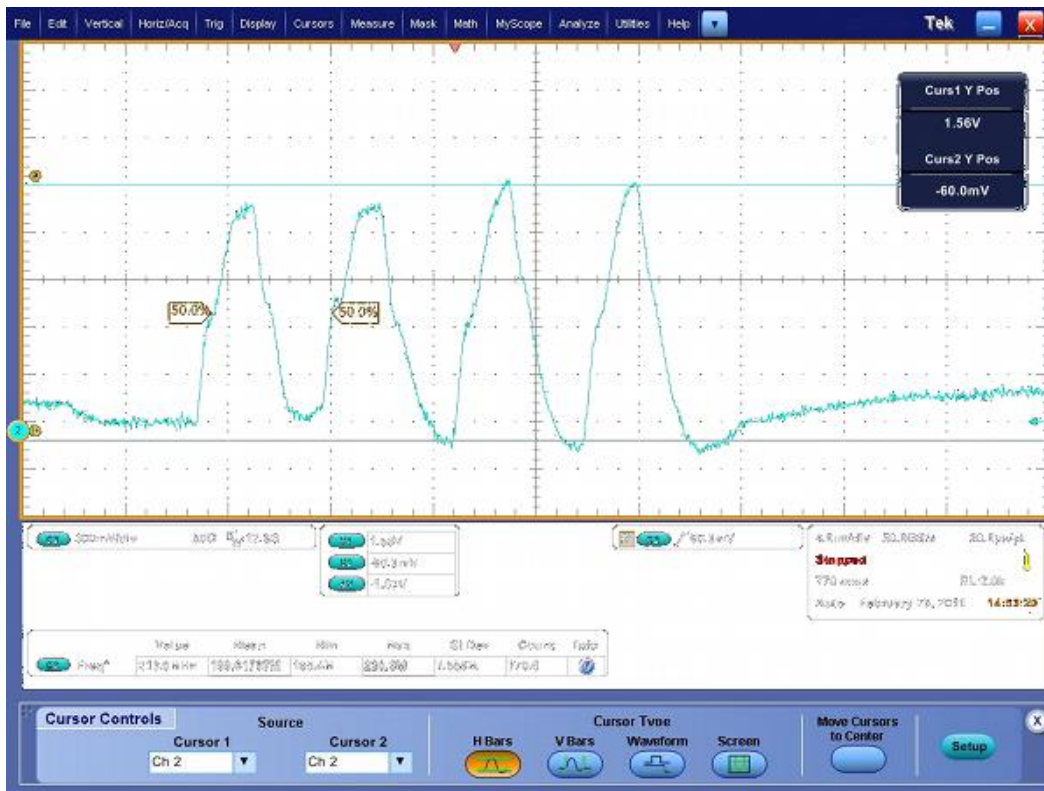

Figure 5: Strobe as seen using the Oscilloscope Component Interposer

Nexus Technology's Component Interposer Advantages

Probed at the BGA Pads

The best place to probe to eliminate reflections associated with standard embedded LPDDR3 mid bus probing or other methods is at the BGA pads. Interposers require no target footprints or special routing requirements that mid bus probing requires.

Use with Existing Embedded Designs

No need to change existing designs. Simply add the interposer to your embedded target with no re-design or added probe points.

Easy to Install

Just install the interposer and riser by using industry standard BGA attachment methods or by utilizing Nexus Technology's attachment service.

Oscilloscope Interposer software

Oscilloscope de-embedding filter software removes the effects of an interposer on the system. Please contact Nexus for more information.

Interposer Riser for the Target

An optional riser can be used to connect the SoC to the interposer. The mechanical dimensions for Riser is shown in Figure 6.

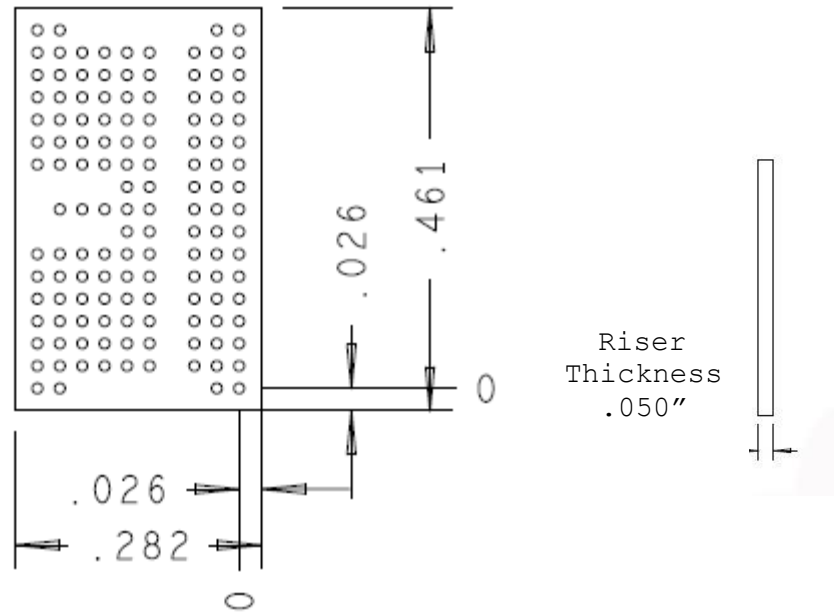

Figure 6: LPDDR2-134 ball Riser Dimensions

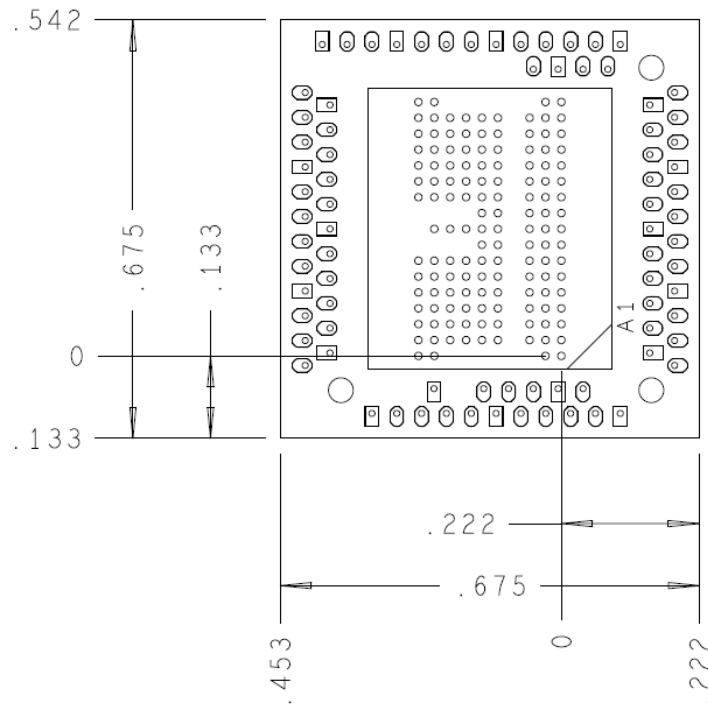

Figure 7: LPDDR2-134 Oscilloscope Component Interposer Dimensions

Product Configuration Tables

LPDDR2 134-ball Oscilloscope Interposers

Nomenclature	Description	Interposer Type	Data Width	Memory Socket Included
NEX-LP2MCI134SCDS	LPDDR2 134 Ball x16/x32 Scope Direct Attach Interposer.	Oscilloscope	x16/x32	No

Optional Add On Accessories

Nomenclature	Description	Solderballs Included
NEX-RSRLPDDR2134	Qty 1: LPDDR2 134 ball riser	No
NEX-OPT-SOLDERBALLS-DA	Qty 1: add solderballs to direct attach interposer	Option
Attachment Service	Nexus provides an optional service for the removal of a memory component from the target under test and the re-balling of the removed memory component as well as the attachment of the riser and interposer onto the user supplied target under test. This attachment is similar to soldering a BGA component onto a Board.	

Further Information

Please contact us by telephone, email or mail as listed below. Normal business hours are 9:00 – 5:00 EST.

Web www.nexustechnology.com
Telephone 877.595.8116
International 603.329.3083
Fax 877.595.8118
Address 78 Northeastern Blvd. Unit 2 Nashua, NH 03062
Email support@nexustechnology.com

**NEXUS**
TECHNOLOGY

